



## Standard Features:

- RoHS compliant
- Light output regulation of +/-0.5% or better.
- 0-5 VDC linear remote control interface, with optional digital interfaces.
- Solid state intensity control (0-100%)
- Universal AC input power
- UL/c-UL, FCC and CE
- Color filtering options
- Easy lamp change
- Cool housing and nosepiece temp.
- Small Footprint
- 2 Year Warranty

## Accessories & Options:

- RS232 interface
- Remote digital analog converter
- IR filter and holder
- Manually adjustable iris

## Model DC950H & DC951H 150 Watt, DC Regulated Illuminator

### Technical Information

<b>Input:</b>	100-240 VAC 50/60 Hz Univ. AC
<b>Lamp:</b>	150 Watt, 21 V, EKE quartz halogen
<b>Lamp Output:</b>	1750 Lumens at fiber optic insertion plane
<b>Color Temperature:</b>	3250° Kelvin at max. intensity
<b>Lamp Life:</b>	200 hrs. at full intensity / up to 10,000 hrs. at lower levels
<b>Fiber Optic Interface:</b>	DC950H - 1.0 in. dia. DC950HB - 0.59 in. dia.
<b>Light Output Regulation:</b>	+/- 0.5% or better
<b>Output Ripple:</b>	0.4% or better
<b>Intensity Control:</b>	Solid state 0-100%
<b>Remote Intensity Control:</b>	0-5 VDC analog, optional 8-bit digital or RS232
<b>Dimensions:</b>	7.25" x 9.50" x 4.69"; 11.5 lbs

### Model Number

<b>DC950</b>	U.S./Canada: 115V Cord
<b>DC951</b>	Europe: 230V Cord

### Option Suffix Description

<b>H</b>	1.0 in. dia. fiber optic interface
<b>HF</b>	Option H, plus IR filter & holder
<b>HR</b>	Option HF, plus manually adjustable iris
<b>HB</b>	0.59 in. dia. fiber optic interface
<b>HBF</b>	Option HB, plus IR filter & holder
<b>HBR</b>	Option HBF, plus manually adjustable iris

# DC950 Dimensions:

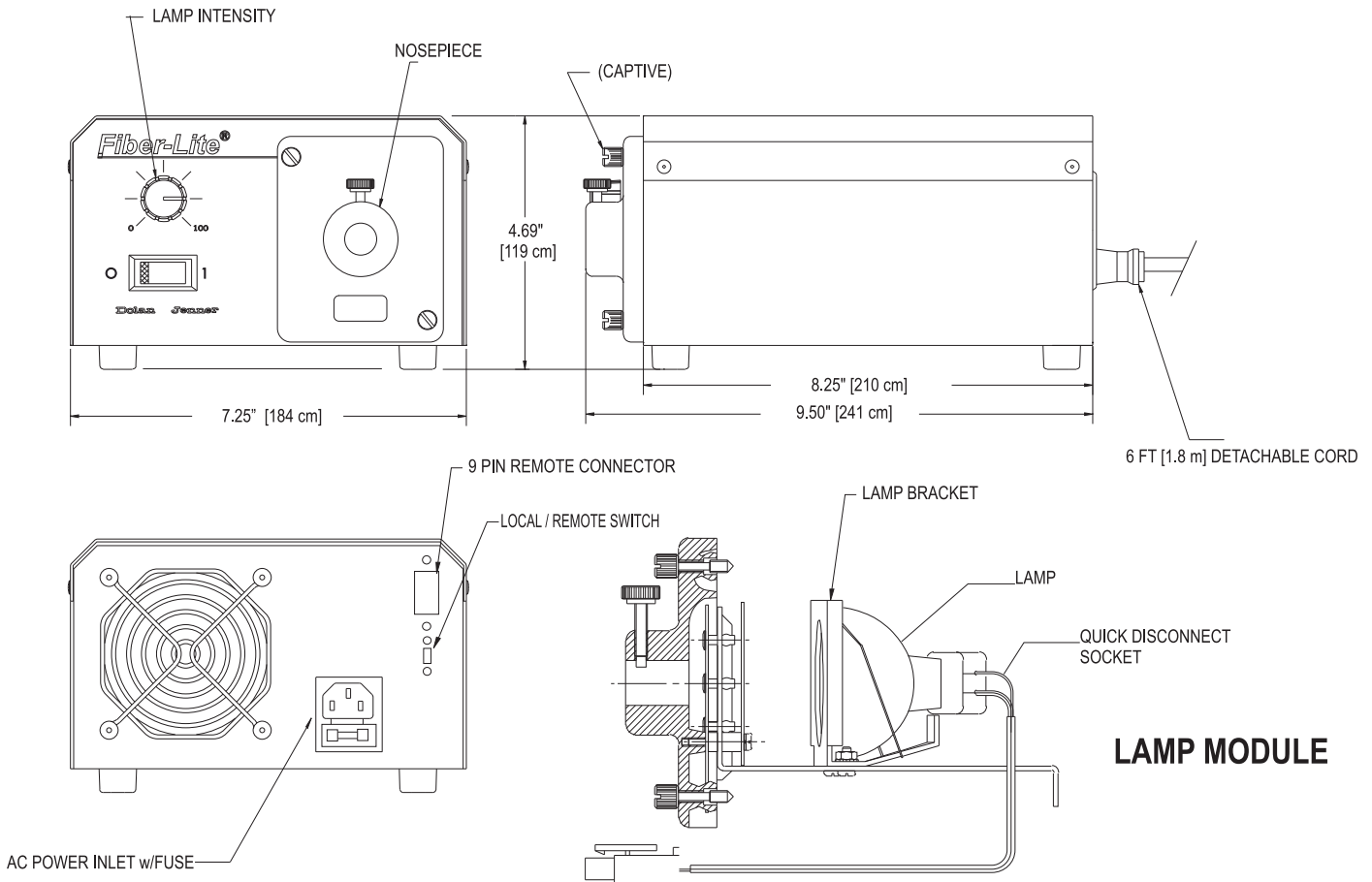

**Dolan-Jenner**  
industries

Dolan-Jenner Industries  
159 Swanson Rd.  
Boxborough, MA 01719 USA

Phone: 800.833.4237  
Fax: 978.264.0292  
Email: support@dolan-jenner.com

**1.800.83.FIBER**

**WWW.DOLAN-JENNER.COM**



### Model DC950 -HR, -HBF & -HBR 150 Watt, DC Regulated Illuminator



#### Standard Features:

- RoHS compliant
- Light output regulation of +/-0.5% or better.
- 0-5 VDC linear remote control interface, with optional digital interfaces.
- Solid state intensity control (0-100%)
- Universal AC input power
- UL/c-UL, FCC and CE
- Color filtering options
- Easy lamp change
- Cool housing and nosepiece temp.
- Small Footprint
- 2 Year Warranty

#### Accessories & Options:

- RS232 interface
- Remote digital analog converter
- IR filter and holder
- Manually adjustable iris

#### Technical Information

<b>Model:</b>	<b>DC950HR</b>	<b>DC950HBF</b>	<b>DC950HBR</b>
<b>P/N:</b>	660001331910	660001341710	660001341910
<b>Input:</b>	100-240 VAC 50/60 Hz Univ. AC		
<b>Lamp:</b>	150 Watt, 21 V, EKE quartz halogen		
<b>Lamp Output:</b>	1750 Lumens at fiber optic insertion plane		
<b>Color Temp.:</b>	3250° Kelvin at max. intensity		
<b>Lamp Life:</b>	200 hrs. at full intensity / up to 10,000 hrs. at lower levels		
<b>Fiber Optic Interface:</b>	1.0 in.	0.59 in.	0.59 in.
<b>Intensity Control:</b>	Solid state 0-100%		
<b>Remote Intensity Control:</b>	0-5 VDC analog, optional 8-bit digital or RS232		
<b>Light Output Regulation:</b>	+/- 0.5% or better		
<b>Output Ripple:</b>	0.4% or better		
<b>Dimensions:</b>	7.25" x 9.50" x 4.69"; 11.5 lbs		

#### Options

<b>IR Filter &amp; Holder:</b>	YES	YES	YES
<b>Manually Adjusted Iris:</b>	YES	NO	YES

# DC950 Dimensions:

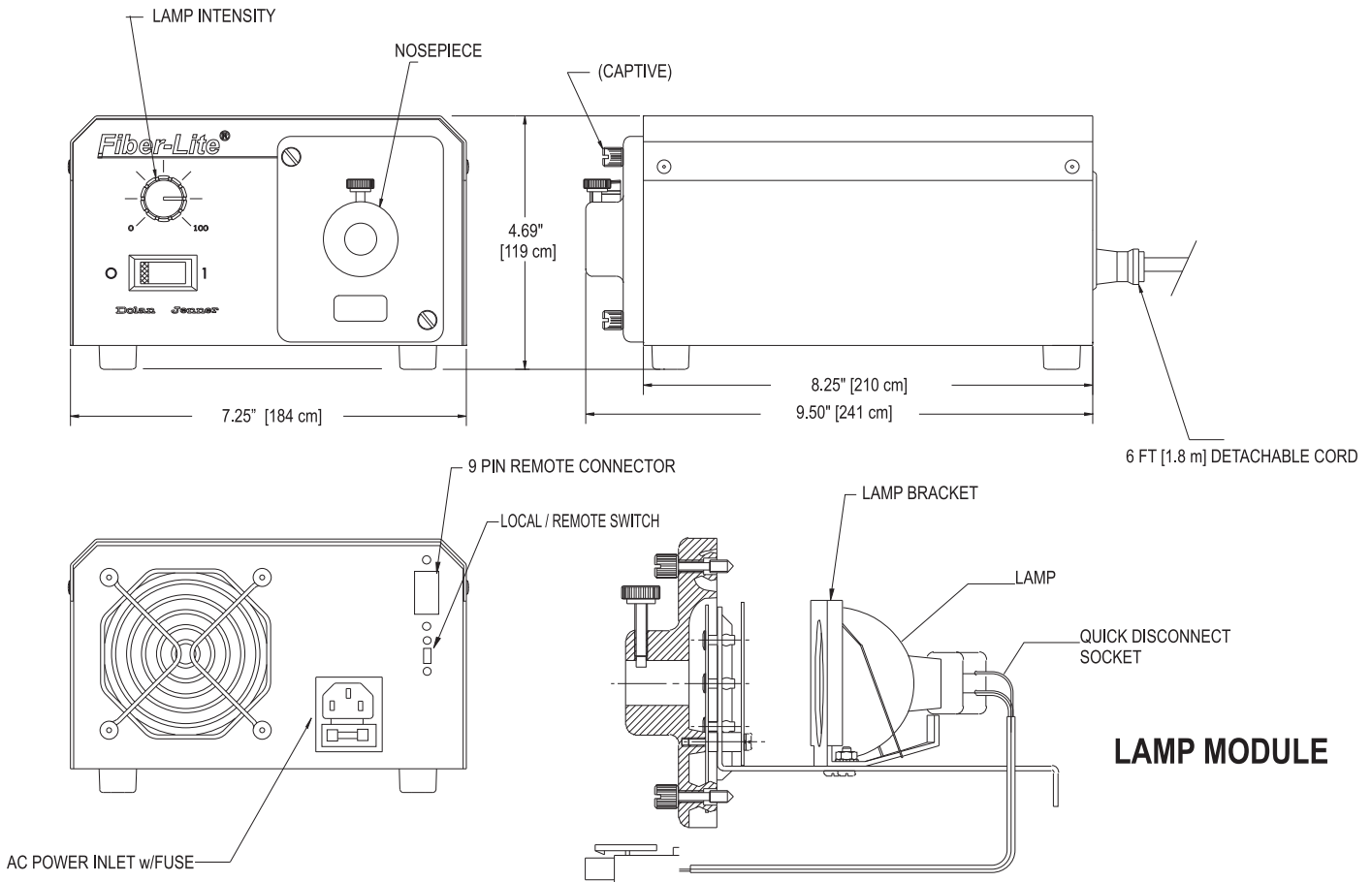

**Dolan-Jenner**  
industries

Dolan-Jenner Industries  
159 Swanson Rd.  
Boxborough, MA 01719 USA

Phone: 800.833.4237  
Fax: 978.264.0292  
Email: support@dolan-jenner.com

**1.800.83.FIBER**

**WWW.DOLAN-JENNER.COM**